

S900/S2000 Stern Windlass

Product manual

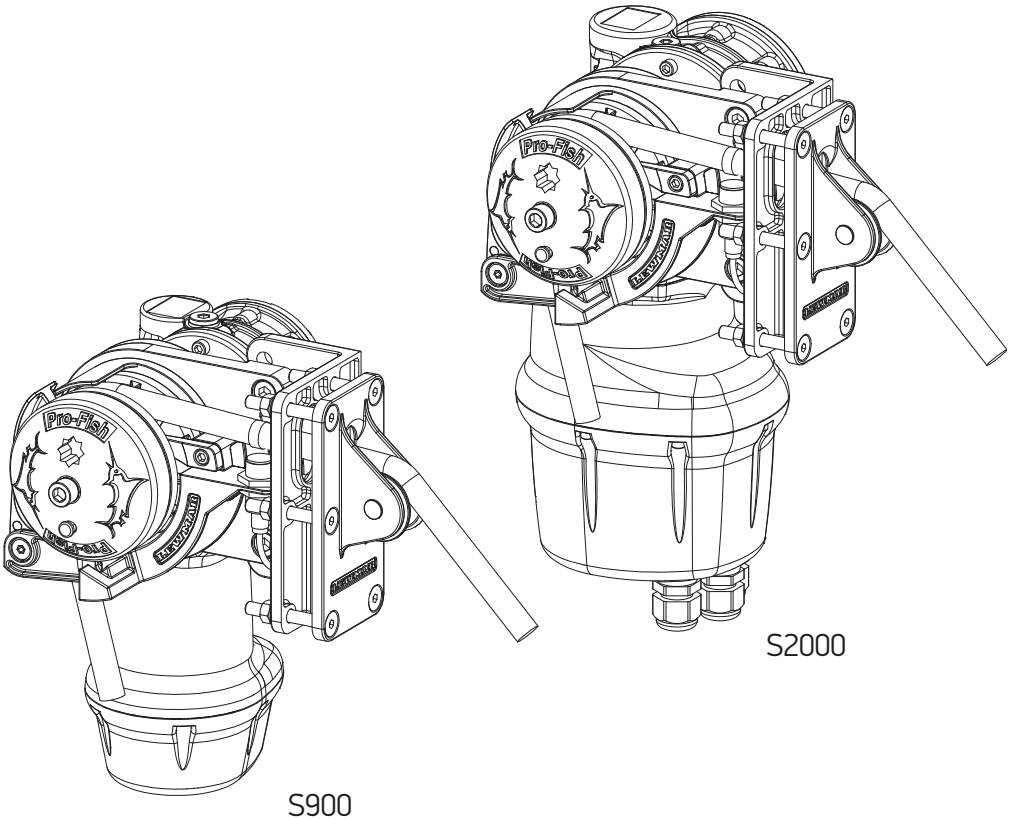

1- Introduction

Thank you for choosing Lewmar. Lewmar products are world renowned for their quality, technical innovation and proven performance. With a Lewmar product you will be provided with many years of outstanding service.

Product support

Lewmar products are supported by a worldwide network of distributors and Authorised Service Representatives. If you encounter any difficulties with this product, please contact your national distributor, or your local Lewmar dealer. Details are available at: www.lewmar.com

CE Approvals

For CE approval certificates contact Lewmar.

Important information about this manual

Throughout this manual, you will see safety and product damage warnings.

You must follow these warnings carefully to avoid possible injury or damage.

2- Specification

2.1 Electric specifications

MODEL	ROPE Ø		MOTOR SUPPLY	MOTOR POWER	MAXIMUM PULL		WORKING LOAD LIMIT		NORMAL CURRENT DRAW	CIRCUIT BREAKER	WEIGHT	
	mm	in	Voltage	Watt	kg	lb	kg	lb	Amp	Amp	kg	lb
S900	12-16	½" - ⅝"	12	600	409	900	102	225	85	90	11.6	26
S2000	12-16	½" - ⅝"	12	1000	910	2000	228	500	100	110	19.9	44

2.2 Gypsy specifications

Specifically designed gypsy to suit leaded lines 12 to 16mm diameter.

2.3 Dimensions

S900

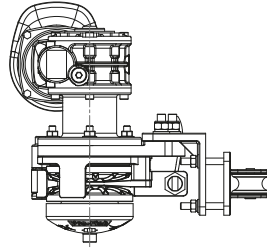
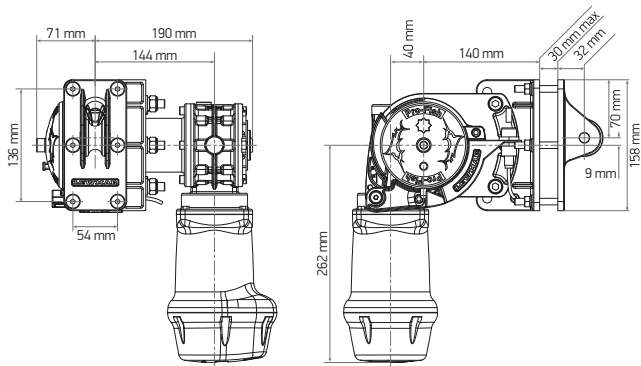

S2000

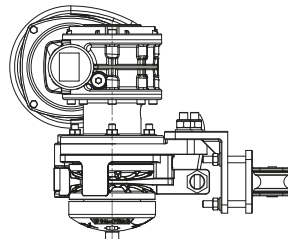
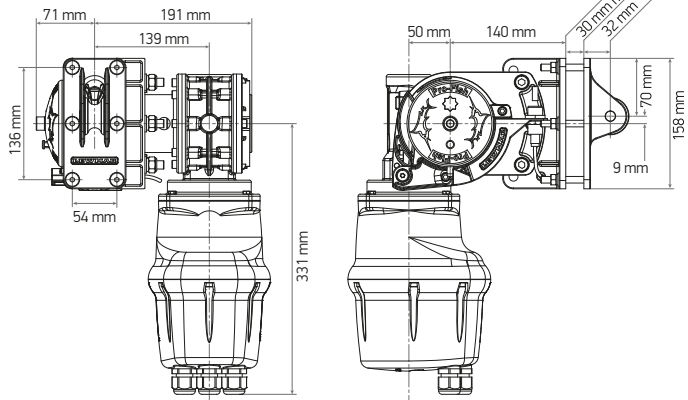

3- Safety Notice

 WARNING!

IMPORTANT: Read these notes before continuing.

3.1 Windlass general

At all times it is the responsibility of the boat user to ensure that the anchor and rode are properly stowed for the prevailing sea conditions. This is particularly important with high-speed powerboats, because an anchor accidentally deploying while under way can cause considerable damage. An anchor windlass is mounted in the most exposed position on a vessel and is thus subject to severe atmospheric attack resulting in a possibility of corrosion in excess of that experienced with most other items of deck equipment. As the windlass may only be used infrequently, the risk of corrosion is further increased. It is essential that the windlass is regularly examined, operated and given any necessary maintenance.

Please ensure that you thoroughly understand the operation and safety requirements of the windlass before commencing the installation. Only persons who are completely familiar with the controls and those who have been fully made aware of the correct use of the windlass should be allowed to use it. If there is any doubt of how to install or operate this unit please seek advice from a suitably qualified engineer.

- Windlasses used incorrectly could cause harm to equipment or crew.
- Windlasses should be used with care and treated with respect.
- Boating, like many other activities can be hazardous. Even the correct selection, maintenance and use of proper equipment cannot eliminate the potential for danger, serious injury or death.
- Lewmar windlasses are designed and supplied for anchor control in marine applications and are not to be used in conjunction with any other use.
- Keep limbs, fingers, clothing and hair clear of windlass and anchor rope/chain and anchor during operation. Severe bodily harm would result.
- Ensure there are no swimmers or divers nearby when dropping anchor.
- When the Windlass is not in use the anchor must be tied off onto a cleat or equivalent strong point to prevent damage to the boat.
- Windlass must not be used as the sole means of securing the anchor to the bow fitting especially under storm conditions. Anchors should be independently secured to prevent accidental release.
- Classification Societies require that a vessel lying at anchor must have its anchor rope/chain secured to a chain stopper or other suitable independent strong point.
- A windlass should never be used as a mooring bollard, the anchor rode **MUST** be secured to a mooring cleat, chain stopper or other designated strong point. Using the windlass to secure the rode will damage the windlass.
- Do not use windlass for ANY purpose other than deployment and recovery of anchor.
- Do not wrap chain around a capstan barrel or drum where fitted.
- A circuit breaker/isolator should always be used with this windlass to protect the motor and cables from overheating and damage.
- Always switch off this windlass at the circuit breaker/isolator when not in use.
- It is the unavoidable responsibility of the owner or master or other responsible party to assess the risk of any operation on the vessel.
- Windlass must not be operated whilst under the influence of alcohol or drugs.

3.2 Fitting

- This equipment must be installed and operated in accordance with the instructions contained in this manual. Failure to do so could result in poor product performance, personal injury and/or damage to your boat.
- Consult the boat manufacturer if you have any doubt about the strength or suitability of the mounting location.

3.3 Electrical

- Make sure you have switched off the power before you start installing this product.
- This product requires installation by a suitably qualified electrical engineer.

4- Installation

4.1 Basic requirements

Each installation requires the following tools:

WINDLASS INSTALLATION

- An appropriate marine sealant
- Electric drill and 9mm (3/8") drill bit
- 50mm (2") Hole Saw
- 5mm (3/16") Allen Key
- 13mm (1/2") Spanner

WIRING INSTALLATION

- Crimping Pliers / Wire Stripper
- Suitable electrical cable and crimp terminals

4.2 Accessories

Use only genuine Lewmar parts and accessories to ensure top performance and eliminate the risk of voiding your warranty. For replacement parts, please visit your dealer or www.lewmar.com

4.3 Bulkhead preparation

IMPORTANT - Plan location carefully at the stern of the vessel and allow for the following:

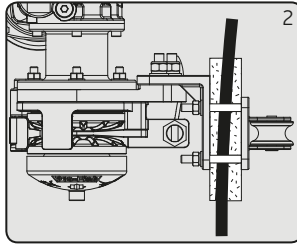
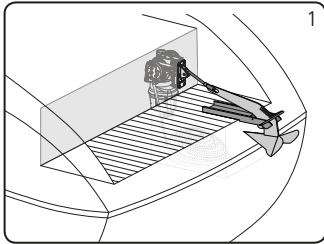

1. Select an appropriate position taking into consideration the position of the anchor roller and the locker behind the bulkhead. Lead from the roller should be fed in-line back to the pulley and along its centre line.
2. If the bulkhead is not flat, a suitable mounting pad may be required to take up camber or sheer.
NOTE: If in doubt about the suitable construction of the pad consult a qualified marine engineer.
The bulkhead is an integral component of the windlass. It has to secure the windlass and be strong enough to cope with the high torque stresses involved in recovering the anchor. Thin bulkhead made of foam or balsa laminate construction, will require reinforcement in order to spread the loads applied while the windlass is in

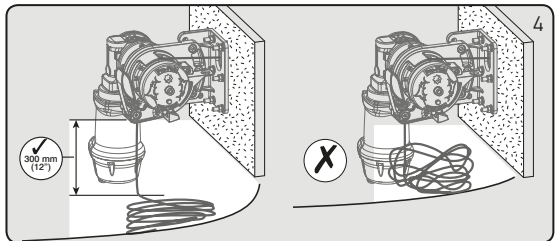
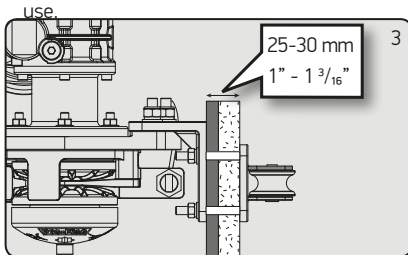

1. Lewmar recommends a minimum bulkhead thickness of 25mm (1"), M8 Screws supplied suit bulkhead and packing thickness of 25-30mm (1" - 1 3/16").
Note: For thicker bulkheads, please source suitable length M8 countersunk screws.
2. Check clearance behind the bulkhead to fit the windlass including the motor gearbox and allow for sufficient vertical fall (minimum of 300 mm / 12" at all times) for the lead line when hauling in.

⚠ WARNING! Failure to provide minimum vertical fall will cause jamming.

4.4 Bulkhead fitting

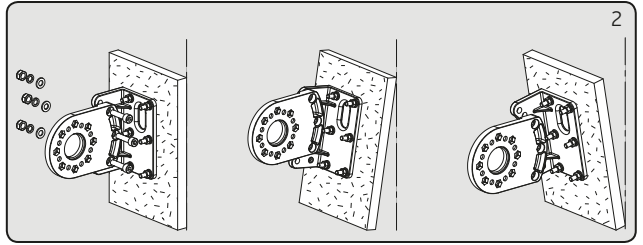
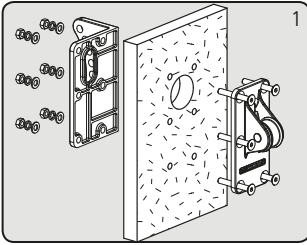

1. Using the template and after you have checked all the bulkhead requirements cut the following holes:

- Using a 9mm ($\frac{3}{8}$ ") diameter drill bit, make the six holes to fit M8 mounting screws.
- With a 50mm (2") diameter hole saw, make one hole for the rode to pass through.
- To help avoid water absorption by the deck, apply an appropriate marine sealant to the freshly cut hole edges.
- Assemble and tighten screws to 21Nm using a 5mm Allen key and 13mm spanner

2. The mounting bracket allows 3 different positions.

Select the desired position depending on the angle of the bulkhead.

- Secure the mounting plate in the chosen position using M10 screws and tighten to 43Nm using an 8mm allen key and 17mm spanner.

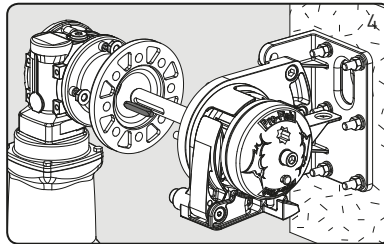
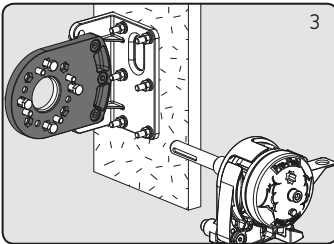

3. Position 4 off gearbox mounting bolts, registering hex heads in recesses of housing, to give desired motor / gearbox position.

- Insert 4 off M8 screws into preferred position and secure main unit. Tighten to 21Nm using a 6mm Allen key
4. Insert key into driveshaft and slide motor / gearbox onto shaft and secure to main unit using 4 off M8 nuts and washers. Torque to 21Nm using a 13mm spanner.

4.5 Loading the anchor rode

⚠ **WARNING!** Isolate (turn off) the windlass using circuit breaker / isolator.

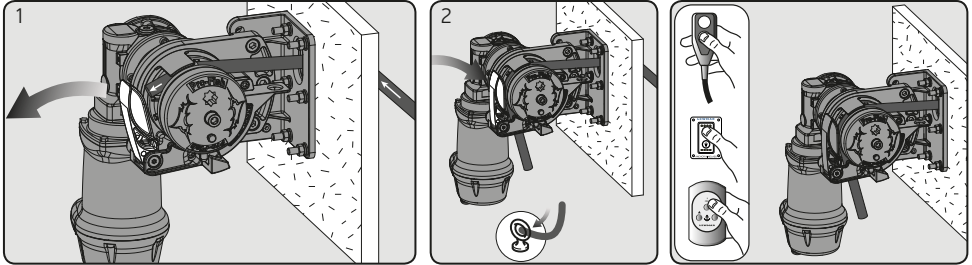

To load the anchor rode:

1. Pass it through the bulkhead roller unit

- Pull back the control arm
 - Pass the rode around the gypsy and down through the bottom channel of the rope guide and into the locker
2. Gently release the control arm to keep the rode engaged in the gypsy.
- Secure end of rode to a suitable strong point.

3. The remainder of the rode can then be powered in.

4.6 Fitting the auto-stop sensor and brass coil

The auto-stop function enables the windlass to stop automatically before the anchor reaches its final stowage position. Allowing careful & controlled anchor stowage.

1. Fit the sensor to the bracket

- Feed the sensor cable through the grommet on the housing
- Secure so that it is clear of any moving parts and falling anchor rode.

2. With the anchor lowered so it is just below water level, adjust the height of the sensor so that it is within 6mm of the anchor rode.

- Mark the rode above the sensor where the wire coil (provided) will be fitted

3. Stow the anchor and cut power.

- Retrieve the rode where previously marked, ready to attach the wire coil

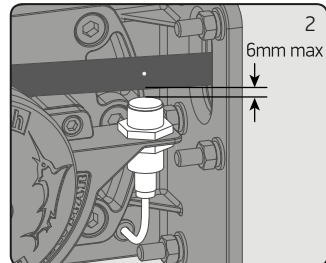
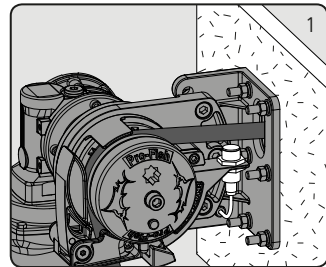

4. Secure the wire coil to the anchor rode as shown in Fig 3.1 to 3.6

- Use an appropriate tool to pierce a hole through the rope.
- Push the brass wire through the rope and fold it lengthwise along the rope
- Wind the free end of the brass wire 8 times around the rope and over the other end of the wire.
- Knot and wind free ends together, trim down to approximately 5mm and secure under the wire wrap.

Note: The outer diameter of the wire wrap should be almost identical as the outer diameter of the rope so that the sensor can detect the brass wire.

The brass wire may become worn by the sheave, especially under heavy load, it must therefore be checked regularly and replaced if necessary.

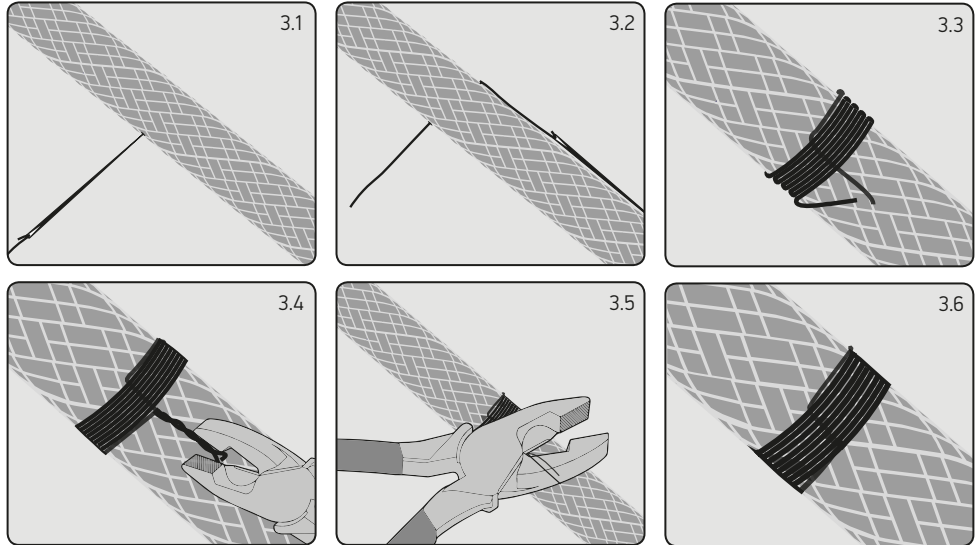

5. Lower the anchor a few metres, then haul in. The Auto-stop will activate, stopping the anchor as it breaks the water.

- The anchor can then be stowed by pulsing the windlass while watching that the anchor is stowing correctly.
- Adjust the sensor height if required.

Note: During use the anchor rode may stretch, so the position of the wire coil may also need adjusting.

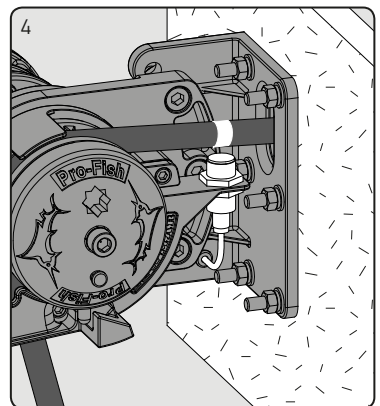

5- Electrical wiring

5.1 Electric cable selection

Lewmar recommends the installer source and install cable that meets the requirements of the standards and regulations relevant to the installation and codes of practice.

The cable table gives recommended cable sizes based on total length of cable required, from the battery, following the route of the cables.

		CABLE SELECTION											
Cable length up to	Feet	7	13	20	26	33	40	46	53	60	66	73	80
	Metres	2	4	6	8	10	12	14	16	18	20	22	24
Cable Size	AWG	8				6				4			
	mm ²	10				16				25			

⚠ DO NOT confuse cable length with the length of the vessel

Windlass performance is directly related to cable size and length.
Voltage drop over the complete wiring run must not exceed 10%.

5.2 Wiring

Plan the installation to suit the controls and give the operator a full view of the windlass. The wiring system should be of the fully insulated type, which avoids possible electrolytic corrosion problems. We recommend the use of type III stranded, tinned copper wire with copper crimp terminals. Most modern installations are negative return (negative ground) but polarity should be checked.

Overload protection, in the form of the circuit breaker provided must be built into the windlass wiring circuit.

- Circuit breaker supplied:
S900 - 90A (Part No 68000349)
S2000 - 110A (Part No 68000350)
- The circuit breaker should be positioned close to the battery in a dry, readily accessible place.
- The breaker must be manually reset should an overload occur that causes it to trip to the off position.

⚠ WARNING!

- If you are not sure you understand these guidelines, seek professional help. Ensure that the installation complies with USCG, ABYC, NMMA or other local regulations.

5.3 Control switch installation

The unit is supplied with

- Guarded rocker switch (product ref 68000593)
- Contactor Assy
 - S900 - 68001213
 - S2000 - 68001214
- Follow wiring diagram 5.4

NOTE: Optional electric footswitches and remote handheld control available.

Visit www.lewmar.com for more information

Optional wireless remote also available

See table below for models and references

WIRELESS REMOTE (3 BUTTON WINDLASS ONLY)	WIRELESS REMOTE (5 BUTTON WINDLASS & THRUSTER)
68000967	68000968

NOTE: In a multi station installation all switches must be wired in a parallel circuit.

5.4 S900 Wiring diagram

Installation instructions are supplied separately with any accessories.

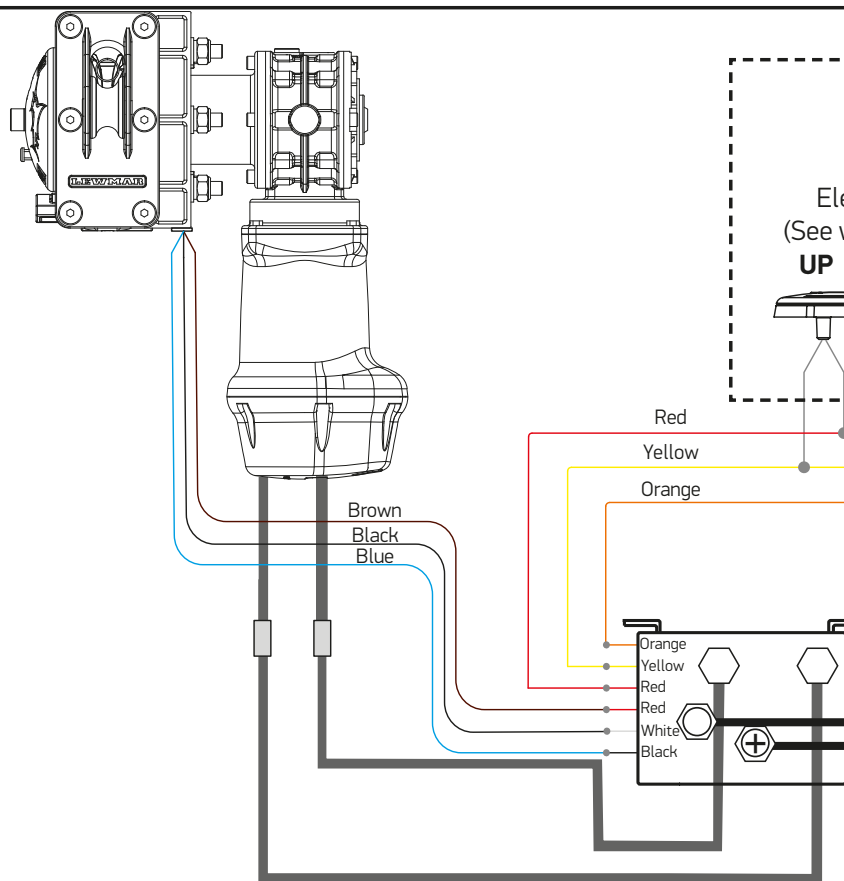

Cable Colours Connections

Orange = Orange

Yellow = Yellow

Red = Red

Brown = Red

Black = White

Blue = Black

Switch wire thickness: 1.5 mm² (16 AWG)

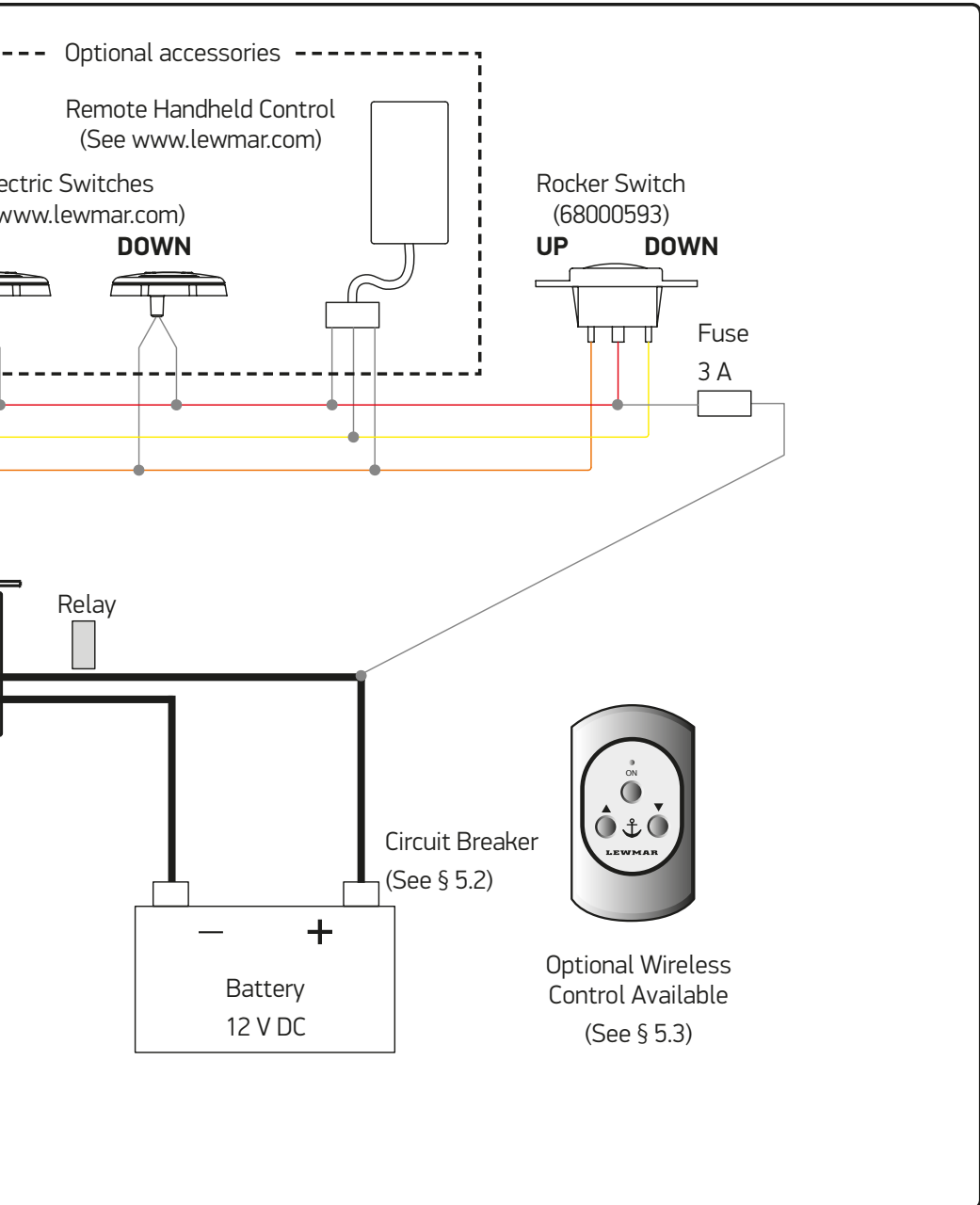

5.5 S2000 Wiring diagram

Installation instructions are supplied separately with any accessories.

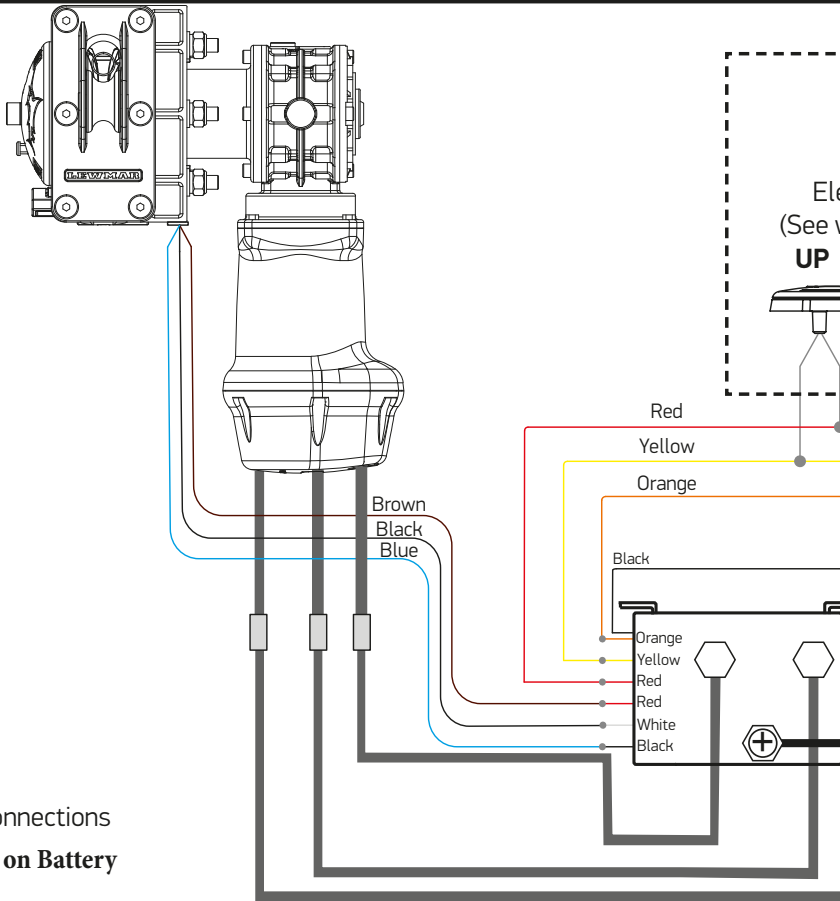

Cable Colours Connections

Black = **Negative on Battery**

Orange = Orange

Yellow = Yellow

Red = Red

Brown = Red

Black = White

Blue = Black

Black = Negative on Battery

Switch wire thickness: 1.5 mm² (16 AWG)

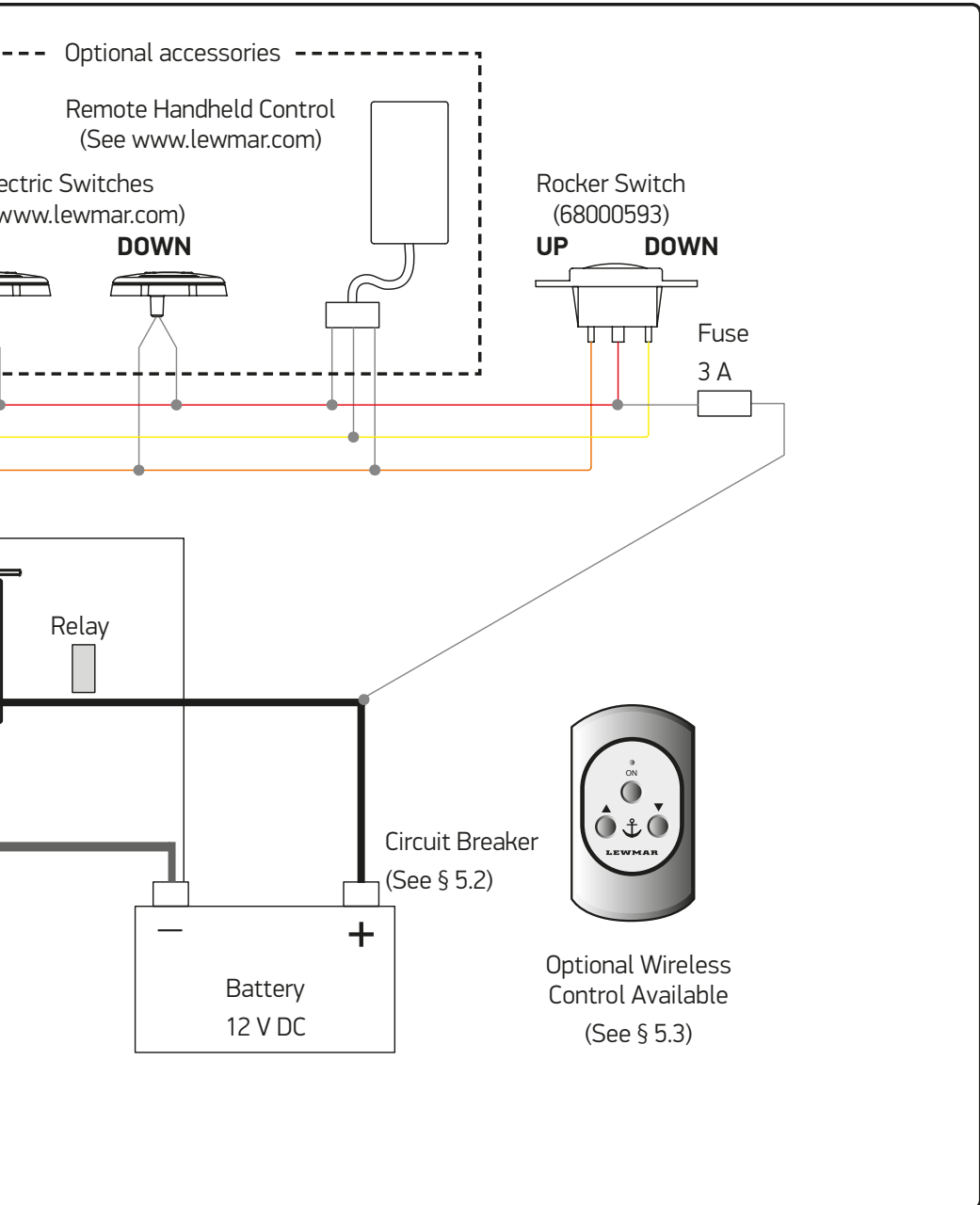

6- Operation

6.1 Manual controlled freefall

Use this method for quicker anchor deployment, in an emergency involving loss of power or to save battery power. Observe maritime anchor deployment safety rules.

⚠ WARNING! Isolate (Turn off) the windlass using circuit breaker / isolator.

⚠ WARNING! Trapping, crushing or entanglement danger whilst operating windlass manually or under power

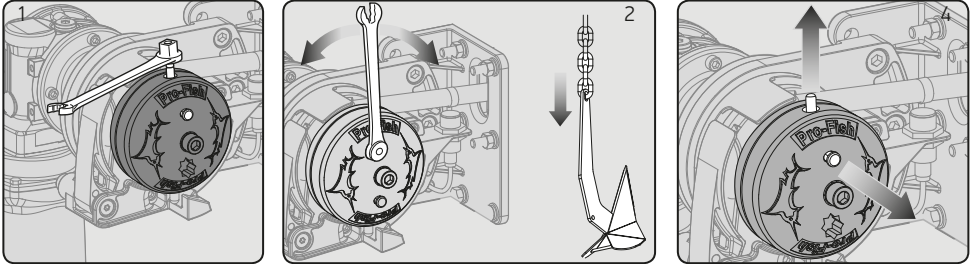

1. Disengage the windlass drive by pressing the plunger button on the windlass drive cap until the plunger remains in the down position.
 - Release the anchor line
2. When safe insert the Lewmar wrench in to the capstan drive cap. Rotate clockwise to grip the gypsy and anticlockwise to free the gypsy controlling the rate of descent of the anchor. Once deployed,

lock the clutch by turning the drive cap clockwise and engage the anchor locks. Remove the wrench handle.

3. To return the windlass back to powered operation pull the locking button out disengaging the plunger. Engage the circuit breaker/isolator and press the UP/DOWN button.

⚠ WARNING! Always remove wrench handle after use

6.2 Power up/down

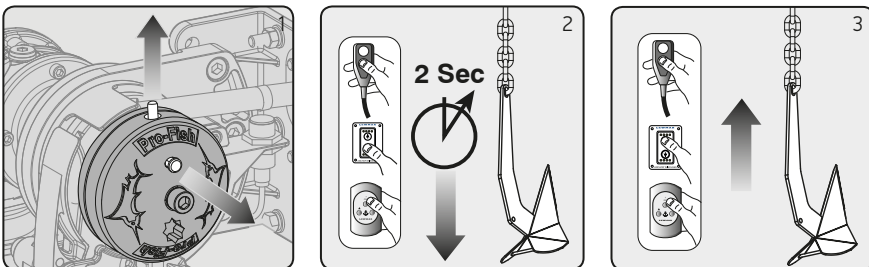

To release anchor:

1. Check unit is not in manual mode and the plunger is disengaged/up position.
2. **Release the anchor line**
 - Engage the circuit breaker/isolator.
 - Press DOWN button for 2 seconds until the anchor is under freefall. If the clutch was left in a locked position the anchor will move almost immediately, if unlocked it could take several seconds to fully re-engage the internal clutch.

- NOTE: Pressing the DOWN button for over 5 seconds will result in a longer clutch re-engagement time during the next UP command.
 - Once enough line has been released press the UP button continuously until freefall stops. It normally takes several seconds to fully re-engage the internal clutch mechanism, locking the windlass.
 - NOTE: Failure to lock the windlass clutch could result in rope creeping out.
3. **To retrieve anchor:** Press the UP button continuously to retrieve the anchor.

7- Servicing

⚠ WARNING! Isolate the windlass using circuit breaker/isolator

⚠ WARNING! Ensure rode is adequately secured to an independent strong point

7.1 Servicing schedule

The service period is determined by the frequency of use. Professional user will need to carry out these operations more often than the weekend user. Before commencing any work on this or any other electrical product, isolate from the power source.

Bedding in period:

When new there are some areas that will need frequent checking. If no movement is found they can be inspected less often.

- Examine all electrical connections, to make sure they are sound and corrosion hasn't set in. Tighten if necessary and protect if required.
- Check mounting screws are firmly clamped and tighten if required.

After use:

- Wash down the windlass using fresh water.
- Ensure rode is at least 12" (300mm) below the windlass
- Check anchor locker drain
- Check rode for wear.

Annually or more often if frequent user:

- Examine all electrical connections, to make sure they are sound and corrosion hasn't set in. Tighten if necessary and protect if required.
- Check mounting screws are firmly clamped and tighten if required.
- Check rode for wear.
- Check gypsy as it is a high wear item (For service and replacement see §7.2)

7.2 Gypsy replacement/service

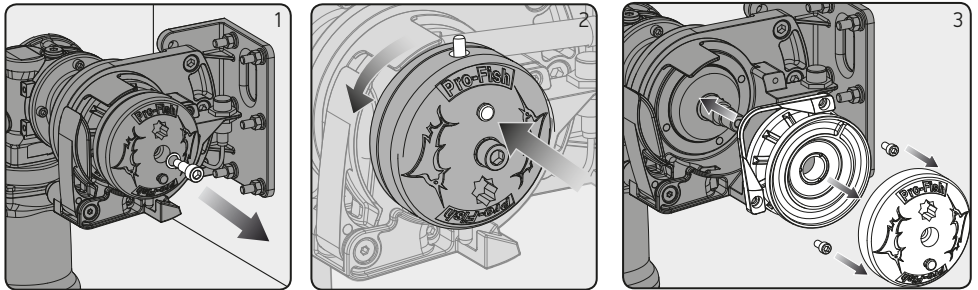

1. Remove screw and washer from drive cap. Screw may require warming as it is sealed with Loctite®
2. Depress plunger so that it is held inside drive cap and unscrew pro-fish mechanism.
3. Remove stripper retaining screws
 - Pull control arm away from the gypsy.
 - Move stripper to clear housing and remove the gypsy, take care to note direction of rope teeth for reassembly.
 - Check parts for wear and replace as appropriate
 - Clean thoroughly without solvent or wire brush and dry.
 - Clean and lubricate Pro-Fish plunger.
 - Re-Assemble, use a small amount of grease on the mating faces.
 - Use loctite® on the assembly screws, making sure no Loctite residue gets on the thread of the driveshaft as it will prevent the free fall function operating. The screws (Fig 3), Retaining the stripper should be tightened, then backed off ½ turn to allow the stripper to lay loose on the gypsy.

7.3 Parts list

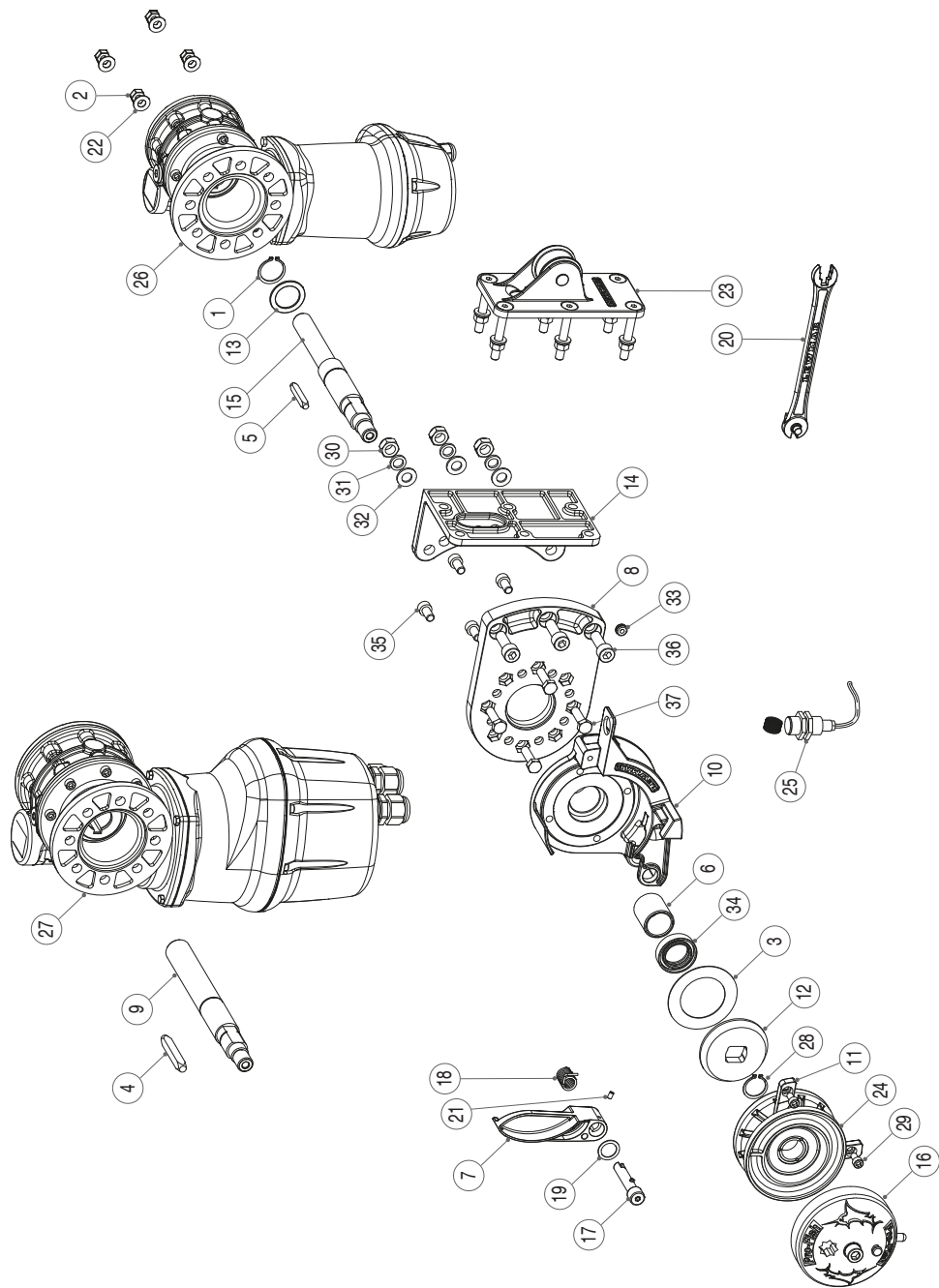

SPARES KIT		
KIT NO	DESCRIPTION	ITEMS INCLUDED (QTY)
66000097	Control arm kit	7(1), 17(1), 18(1), 19(1), 21(1)
66000099	Clutch lever	20 (1)
66000620	Pro-Fish drive cap	16 (1)
66000807	Bulkhead unit	23(1)
66000808	Mounting bracket kit	8(1), 14(1), 30(3), 31(3), 32(3), 33(1), 36(3)
66000809	Stopper cam / Rope guide kit	6(1), 10(1), 34(1), 35(4)
66000810	Gypsy	24(1)
66000811	Stripper kit	11(1), 29(2)
66000812	Drive cone kit	3(1), 12(1), 28(1)
66000813	600 W driveshaft kit	1(1), 5(1), 13(1), 15(1)
66000814	1 kW driveshaft kit	1(1), 4(1), 9(1), 13(1)
66001190	Autostop	25(1)
66000816	600 W Motor/Gearbox	2(4), 22(4), 26(1), 37(4)
66000817	1 kW Motor/Gearbox	2(4), 22(4), 27(1), 37(4)

8- Troubleshooting

1. Anchor rode pays out independently while windlass is not in use.
 - This problem is a result of not securing the rope combined with the gypsy drive cap being slack. Tighten the gypsy drive cap using the winch handle and always secure the rope independently of the windlass when not in use.
2. Failure to operate or sluggish operation.
 - The majority of these problems are electrical in nature. It is essential that the proper voltage be maintained. The proper voltage on a 12 Volt system is 13.5 Volts, constant low voltage will damage motor.
 - Ensure electrical cable size is large enough to handle the current draw and keep voltage drop within acceptable limits.
 - Check control switches, connections, battery condition, isolator switch, fuse and motor for operation failure.
3. Failure to operate.
 - Is there a voltage at the input terminals to the contactor and switches.
Check the circuit breaker/isolator switch and any fuses.
 - Operate the switch. Is there voltage at the positive switch terminal on the solenoid.
If not, the switch (or its wiring), is defective.
 - Keep the switch activated. Is there voltage at the main output terminal on the contactor.
If not check the contactor coil ground circuit. If okay, replace the contactor.
 - Check the voltage at the motor. If voltage of at least 12.5 volts is present and the motor does not operate, the motor is defective.

9- Warranty

Limited Warranty and Key Terms of Supply by Lewmar

Lewmar warrants that in normal private pleasure boat usage and with proper maintenance its products will conform with their specification for a period of three years from the date of purchase by the end user, subject to the conditions, limitations and exceptions listed below. Any product, which proves to be defective in normal usage during that three-year period, will be repaired or, at Lewmar's option, replaced by Lewmar.

A CONDITIONS AND LIMITATIONS

- i Lewmar's liability shall be limited to the repair or replacement of any parts of the product which are defective in materials or workmanship.
- ii Responsibility for the selection of products appropriate for the use intended by the Buyer shall rest solely with the Buyer and Lewmar accepts no responsibility for any such selection.
- iii Lewmar shall not be liable in any way for Product failure, or any resulting loss or damage that arises from:
 - a. use of a product in an application for which it was not designed or intended;
 - b. corrosion, ultra violet degradation or wear and tear;
 - c. a failure to service or maintain the product in accordance with Lewmar's recommendations;
 - d. faulty or deficient installation of the product (unless conducted by Lewmar);
 - e. any modification or alteration of the product;
 - f. conditions that exceed the product's performance specifications or safe working loads.
- g. Abuse
- iv Product subject to a warranty claim must be returned to the Lewmar outlet that supplied the product for examination unless otherwise approved by Lewmar in writing.
- v This warranty does not cover any incidental costs incurred for the investigation, removal, carriage, transport or installation of product.
- vi Service by anyone other than authorized Lewmar representatives shall void this warranty unless it accords with Lewmar guidelines and standards of workmanship.
- vii Lewmar's products are intended for use only in the marine environment. Buyers intending to use them for any other purpose should seek independent professional advice as to their suitability. Lewmar accepts no liability arising from such other use.

B EXCEPTIONS

Cover under this Warranty is limited to a period of one year from the date of purchase by the end user in the case of any of the following products or parts of products:

- Electric motors and associated electrical equipment
- Electronic controls
- Hydraulic pumps, valves and actuators
- Hatch & Portlight weather seals
- Products used in "Grand Prix" racing applications
- Products used in commercial or charter applications
- Anchor rode

C LIABILITY

- i Lewmar's liability under this warranty shall be to the exclusion of all other warranties or liabilities (to the

extent permitted by law). In particular (but without limitation):

- a. Lewmar shall not be liable for:
 - Any loss of anticipated turnover or profit or indirect, consequential or economic loss;
 - Damages, costs or expenses payable to any third party;
 - Any damage to yachts or equipment;
 - Death or personal Injury (unless caused by Lewmar's negligence).

Some states and countries do not allow the exclusion or limitation of incidental or consequential damages, so the above limitation or exclusion may not apply to you

- b. Lewmar grants no other warranties regarding the fitness for purpose, use, nature or satisfactory quality of the products.
- ii Where applicable law does not permit a statutory or implied warranty to be excluded, then such warranty, if permitted by that state or country's law, shall be limited to a period of one year from the date of purchase by the end user. Some states and countries do not allow limitations on how long an implied warranty lasts, so this limitation may not apply to you.

D PROCEDURE

Notice of a claim for service under this warranty shall be made promptly and in writing by the end user to the Lewmar outlet that supplied the product or to Lewmar Limited at Southmoor Lane, Havant, Hampshire PO9 1JJ, England.

E SEVERANCE CLAUSE

If any clause of this warranty is held by any court or other competent authority to be invalid or unenforceable in whole or in part, the validity of the remaining clauses of this warranty and the remainder of the clause in question shall not be affected.

F OTHER RIGHTS

This warranty gives you specific legal rights, and you may also have other legal rights, which vary from state to state and country to country. In the case of European States a Consumer customer (as defined nationally) has legal rights under the applicable national law governing the sale of Consumer Goods; this Warranty does not affect those rights.

G LAW

This warranty shall be governed by and read in accordance with the laws of England or the state or country in which the first end user is domiciled at the time of purchase of the product.

H DISPUTES

Any dispute arising under this warranty may, at the option of the end-user, be referred to alternative dispute resolution under the rules of the British Marine Federation or to the Courts of the State whose law shall govern the warranty or to the Courts of England and Wales.

The British Marine Federation may be contacted at Marine House, Thorpe Lea Road, Egham, England, TW20 8BF

NOTES:

UK & International Distribution

Lewmar Ltd
Southmoor Lane
Havant
Hampshire
PO9 1JJ
England

Tel: +44 (0)23 9247 1841

Fax: +44 (0)23 9248 5720

Email: info@lewmar.com

USA

351 New Whitfield Street
Guilford, CT
06437
USA

Tel: +1 203 458 6200

Fax: +1 203 453 5669

Email: info@lewmarusa.com

LEWMAR®

www.lewmar.com

Part No B10500 iss.1